

# Linear Motion

## Linear Heads

### Characteristics of Linear Heads

The three major characteristics of linear heads are rack speed, maximum transportable mass and holding force.

### Rack Speed

The linear motor's rack speed is shown in the specifications table for each product. Rack speed is expressed as "basic speed." The basic speed is calculated on the basis of the motor's synchronous speed (e.g., 1500 r/min at 50 Hz). The actual motor speed varies, depending on the size.

The rack speed can be calculated based on the speed of the motor used, using the equation below.

$$V = Ns \times \frac{1}{60} \times \frac{1}{i} \times \pi DP$$

- $V$  : Rack moving speed (mm/s)
- $Ns$ : Speed of the motor used (r/min)
- $i$  : Gear ratio of the linear head's speed-reduction section → See table below.
- $DP$ : Pinion-pitch circle diameter (mm) → See table below.

### Maximum Transportable Mass

The thrust force can be calculated based on the torque of motor combined using the equation below. However, in the case of a high gear ratio or use in a horizontal direction, the solution obtained by the equation will indicate a thrust force sufficient to drive the load mass in excess of the gear's mechanical strength. Make sure the linear head's load mass is at or below its maximum transportable mass, regardless of the rack's direction of movement.

$$F = T_m \times i \times \eta_1 \times \frac{2}{DP} \times \eta_2$$

$$W = F/9.807$$

- $T_m$ : Motor torque (mN·m)\*
- $F$  : Thrust force (N)
- $W$  : Weight capacity (kg)
- $i$  : Gear ratio of the linear head's speed-reduction section → See table below.
- $\eta_1$  : Transmission efficiency as determined by gear ratio → See table below.
- $DP$ : Pinion-pitch circle diameter (mm) → See table below.
- $\eta_2$  : Transmission efficiency of rack and pinion (=0.9)

\*For motor torque, choose the lesser of starting torque of rated torque.

Any calculated thrust force is the value for horizontal rack movement. The value for vertical movement can be obtained by subtracting the rack's mass (see dimensional drawing) or its mass-based force (rack's mass × 9.807) from the thrust force.

Linear Head Model	Gear Ratio $i$	Transmission Efficiency $\eta$	Pinion Pitch Diameter $DP$ (mm)
<b>0LB (F) 20N</b> -□	30	0.66	7.5
<b>0LB (F) 10N</b> -□	50	0.66	
<b>0LB (F) 5N</b> -□	100	0.59	
<b>2LB (F) 50N</b> -□	17.68	0.73	12
<b>2LB (F) 25N</b> -□	35.36	0.66	
<b>2LB (F) 10N</b> -□	86.91	0.59	
<b>4LB (F) 45N</b> -□	36	0.73	21.25
<b>4LB (F) 20N</b> -□	75	0.66	
<b>4LB (F) 10N</b> -□	150	0.66	
<b>5LB (F) 45U</b> -□	36	0.66	24
<b>5LB (F) 20U</b> -□	90	0.59	
<b>5LB (F) 10U</b> -□	180	0.59	

### Holding Force

The following equation is used to calculate the holding force of the linear head when connected to a motor.

$$F_B = T_B \times i \times \frac{2}{DP}$$

- $F_B$ : Holding force (N)
- $T_B$ : Holding torque of motor used (mN·m)
- $i$  : Gear ratio of the linear head's speed-reduction section → See table to the left
- $DP$ : Pinion-pitch circle diameter (mm) → See table to the left

Any holding force listed in the specifications table or any calculated holding force is the value for horizontal rack installation. The value for vertical installation can be obtained by deducting the rack's mass-based force (see dimensional drawing) (rack's mass × 9.807) from holding force.

### Rack Play (initial values)

The linear head rack is supported at two places by oilless metal grommets in the rack case. Because the rack passes through the inside of the grommets, a slight gap has been left between the grommet and the rack. Therefore, the rack is subject to play, as shown in the figure below.

- Play in directions A and B has been measured at a point 500 mm from the case surface. Since the rack is round-shaped, play in the D direction is large.
- The rack play indicates an initial value which will increase during operation. If the rack play becomes a problem, install an external guide.

Direction A or B	2 mm max.
Direction C	0.5 mm max.
Direction D	5° max.

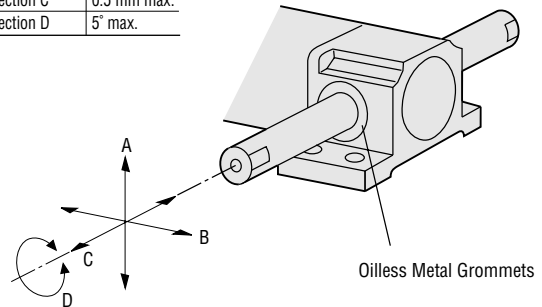

## Repetitive Positioning Accuracy of Compact Actuators DRL Series

Take proper precautions in order to ensure observance of the repetitive positioning accuracy requirements provided in the specifications.

### ① Sufficient Rigidity for Peripheral Equipment

- The linear guides and other mechanical components to be used with the actuator should have rigidity sufficient to withstand the load mass and external forces. Insufficient rigidity may cause deflection, which will prevent the actuator from meeting the requirements defined in the specifications.
- The mounting brackets used for installation of the actuator and the work piece attachment brackets should also have rigidity sufficient to withstand the load mass and external forces. Insufficient rigidity may cause deflection, which will prevent the actuator from meeting the requirements defined in the specifications.

### ② Sensor

- Use a high-accuracy home position sensor (e.g. photomicrosensor). Home positioning accuracy is not included as part of the repetitive positioning accuracy.

### ③ Temperature Rise in Actuator

- The actuator may generate a significant amount of heat, depending on the drive conditions. The heat thus generated will cause the internal ball screw to elongate, resulting in displacement as shown in the figure below (reference data). To minimize the temperature dependent effects on the repetitive positioning accuracy, control the input current to the actuator and provide a design that allows for adequate heat ventilation in peripheral areas.

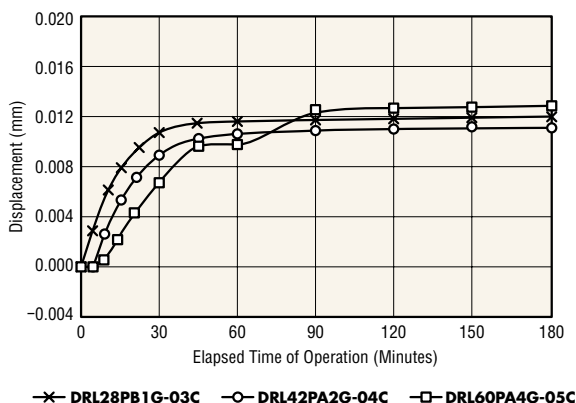

Conditions

Current down : Off

Operation duty : 80%

Measurement method: Using a laser displacement meter.

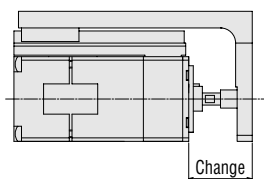

## Glossary

### ● Maximum Overhung Load

This is the load that can be applied to the rack in a direction perpendicular to the rack axis. If a load is applied continuously to the end of the rack, then the weight of that load will be applied to the rack as an overhung load.

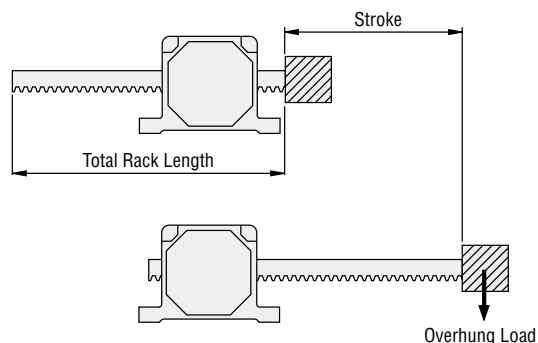

### ● Dog

The function of dogs is to trip limit switches and sensors. Dogs are attached to the rack to set the position where the rack should stop.

### ● Rack

A gearcut rod is made of S45C or equivalent grade of steel and has a surface treated with nitride. Racks for linear motors are specially designed and machined, and have special cross sections. Those for linear heads have round cross sections.

Motor and Fan Sizing

Service Life

Standard AC Motors

Brushless DC Motors

Stepping Motors

Gearheads

Linear Motion

Fan Motors